

AEROEVAPORATORI A SOFFITTO
Ceiling unit coolers



RIVACOLD

Tabella / Table

(A)	RS1040 RS1040B RS1040BED RS1060 RS1060B RS1060BED
(B)	RS2100 RS2100B RS2100BED RS2130 RS2130B RS2130BED
(C)	RS3180 RS3180B RS3180BED RS3290 RS3290B RS3290BED
(D)	RS4380 RS4380B RS4380BED



(A)



(B)



(C)



(D)

Aeroevaporatori a soffitto RS

RS Ceiling unit coolers

Caratteristiche generali

Gli aeroevaporatori della serie RS sono stati ideati per essere installati all'interno di celle frigorifere per la conservazione di prodotti freschi e congelati. La forma estremamente compatta permette l'installazione anche in celle di dimensioni ridotte. Tutti i modelli sono realizzati con geometria 25x22 e tubo 3/8". Gli RS sono disponibili in due versioni: versione per media/alta temperatura (passo alette 3,5/7mm differenziato) e versione per bassa temperatura, (passo alette 4,5/9mm differenziato). Nei modelli di media/alta temperatura non è prevista la versione con resistenza montata; per questi modelli la resistenza deve essere richiesta a parte e verrà fornita in dotazione. Per la scelta delle resistenze vedere la tabella di abbinamento qui sotto riportata. I modelli a bassa temperatura sono disponibili nella versione senza resistenza (mod. RS...B) e nella versione con resistenza montata e cablata su scatola di derivazione (mod. RS...BED).

General features

RS range unit coolers have been designed to be installed inside cold rooms suited for fresh and frozen goods storage. Their shape, being extremely compact, make their installation possible also in cold rooms having very small dimensions.

All models are made with 25x22 geometry and 3/8" tube. RS range unit coolers are available in two main versions: the one suited for medium/high temperature (differentiated fin spacing 3,5/7mm); the other version suited for low temperature application (differentiated fin spacing 4,5/9mm). In model for medium/high temperature the version with the fitted defrosting heater is not available; for these models the heaters has to be requested separately and they will be supplied not mounted. For the choice of the proper heater, see the table shown here below. The models for low temperature application are available in the version supplied without defrosting heater (mod. RS...B) and with defrosting heater mounted and wired on the unit cooler's terminal box as well (mod. RS...BED).

Optional - Optional items

- Resistenza di sbrinamento
Defrosting heater
- Batteria verniciata con vernice a polvere epossidica (es. cod. RS1040-VT)
Varnished coil by epoxy powder varnish (egs. cod. RS1040-VT)
- Resistenza per il tubo di scarico
Drainage pipe heater

Scelta delle resistenze di sbrinamento Defrosting heater choice

Modello RS RS range	Codice resistenza Heater code
RS1040...	REVS40
RS1060...	REVS60
RS2100...	REVS100
RS2130...	REVS130
RS3180...	REVS180
RS3290...	REVS290
RS4380...	REVS380

Caratteristiche costruttive



Manufacturing features

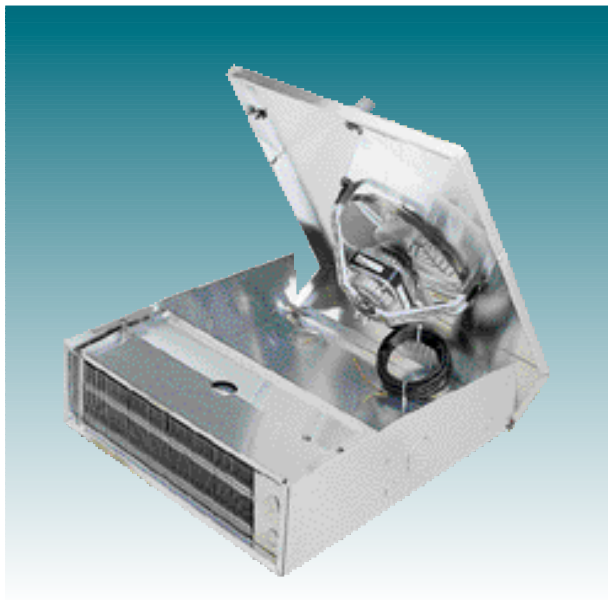

Tutti i modelli hanno di serie lo sgocciolatoio montato che va a coprire completamente la batteria fino alle curvette.

All models are equipped with fitted drip tray that covers completely the coil up to the bends.

Mod. RS...BED con resistenza montata e cablata su scatola di derivazione.

RS...BED model with defrosting heater mounted and wired on the unit cooler's terminal box.

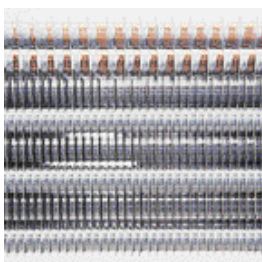
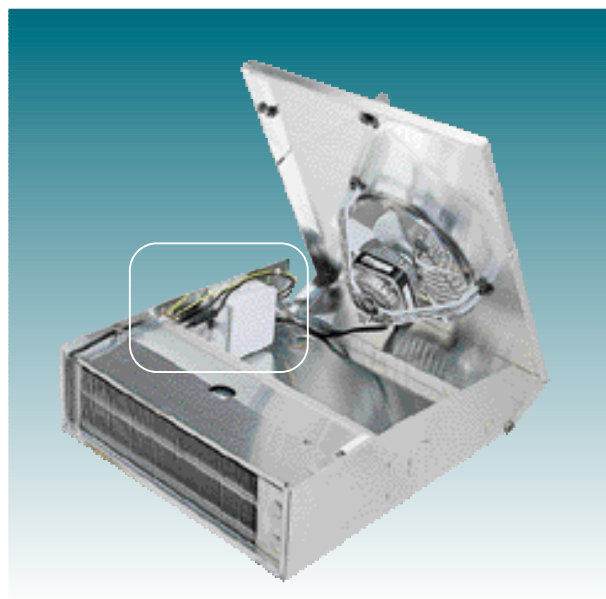

Batteria con passo alette differenziato.

Coil with differentiated fin spacing.



Griglia e staffe di supporto in plastica.

Grid and brackets made of plastic.



Caratteristiche costruttive

Manufacturing features

Batteria

La batteria è costruita con alette in alluminio e tubo in rame da 3/8".

Essa viene collaudata con azoto ad una pressione di 25 bar.

Motoventilatore

Il motoventilatore utilizzato ha le seguenti caratteristiche:

- costruito nel rispetto delle norme EN 60335-1, con protezione termica interna
- flusso aria aspirante
- griglia e staffe di supporto in plastica
- diametro ventola 200 mm, inclinazione 34°
- alimentazione 230-240V/1/50-60Hz
- grado di protezione IP44
- temperatura di funzionamento da -40°C a +40°C
- classe di isolamento B
- esecuzione elettrica conforme alla direttiva 73/23 CEE Bassa Tensione

Carenatura

E' realizzata in alluminio. Le soluzioni costruttive adottate conferiscono robustezza alla carenatura e garantiscono l'assenza di vibrazioni durante il funzionamento. Le viti, le rondelle e i dadi sono di acciaio inossidabile.

Tutti gli RS vengono forniti con lo sgocciolatoio già montato.

Coil

The coil is made of aluminium fins and 3/8" copper tube.

It is tested with nitrogen at a pressure of 25 bar.

Fan motor

The fan motor model in use has the following features:

- manufactured following EN 60335-1 laws, with internal thermal protection
- draw through air flow
- grid and brackets made of plastic
- fan diameter 200mm, 34° inclination
- power supply 230-240V/1/50-60Hz
- IP44 protection rate
- operating temperature from -40°C to +40°C
- B insulation class
- electrics made in conformity with 73/23 CEE Low Tension directive

Housing

The housing is made of aluminium. The manufacturing solutions used give the housing strength and guarantee the absence of vibrations during the functioning.

Screws, washers and nuts are made of stainless steel. All RS models are supplied with the drip tray already fitted.

Scelta evaporatore

Model choice

Per una corretta scelta dell'evaporatore, utilizzare le tabelle "Potenza Frigorifera".

Nelle tabelle sono riportate le rese frigorifere calcolate per una temperatura cella che va da -5°C a +12°C per i modelli con passo alette 3,5/7mm e da -35°C a 0°C per i modelli con passo alette 4,5/9mm. Per tutti i modelli, il ΔT (differenza tra la temperatura dell'aria in entrata e la temperatura di evaporazione del refrigerante) va da 5 a 10 e si utilizza come refrigerante gas R404A. Impiegando altri refrigeranti, la capacità va moltiplicata per il fattore correttivo di seguito riportato: R22=0,93 ; R134a=0,91 ; R507/R404A=1. I parametri per la scelta dell'evaporatore sono: la temperatura della cella, il valore ΔT ed il carico termico. Nella colonna corrispondente alla temperatura cella desiderata cercheremo il modello che, in corrispondenza del ΔT richiesto, avrà una resa uguale o superiore al carico termico.

For a correct choice of the unit cooler, use the "refrigerating output" tables.

In these tables are quoted the refrigerating capacities calculated for a cold room temperature ranging from -5°C to +12°C for models having their fin spacing of 3,5/7mm and from -35°C to 0°C for models having their fin spacing of 4,5/9mm. For all models the ΔT (i.e. difference between the inlet air temperature and the gas evaporating temperature) ranges from 5 to 10 by using R404A gas. In case of a different gas in use, the capacity is to be multiplied by the relevant corrective factor : R22 = 0,93; R134a = 0,91; R507/R404A = 1. The parameters valid for the unit cooler choice are the following ones: the cold room temperature, the ΔT value and the heat load. In the column corresponding to the requested cold room temperature we will check the model that, matching the line of the requested ΔT , will have a capacity equal or bigger than the heat load.



Caratteristiche costruttive



Manufacturing features

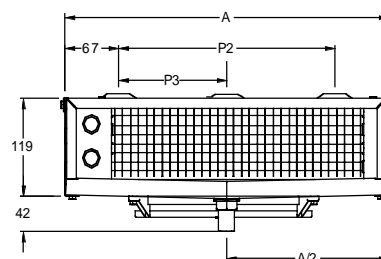
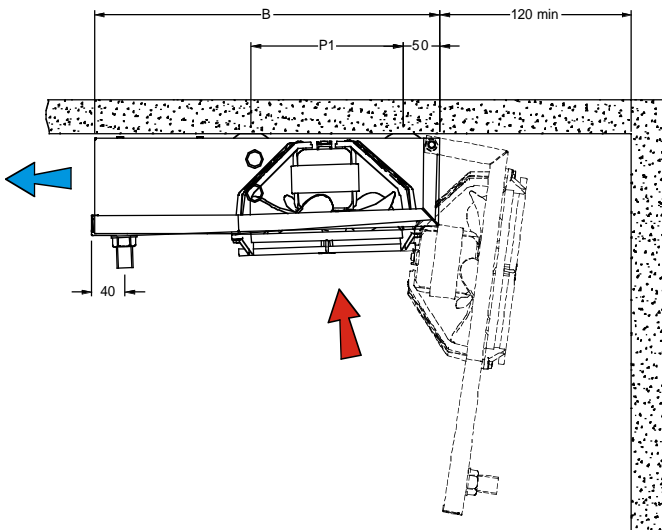

Asole di fissaggio
Fixing slots

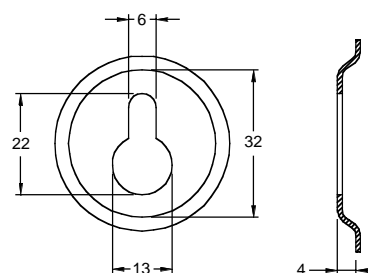

Facilmente accessibile in caso di manutenzione grazie al convogliatore/bacinella che può aprirsi a 90°
Easily accessible in case of maintenance thanks to the conveyor/tray that can be opened up to 90°

Serie RS / RS Range

Modello Model	RS	1040 1040B 1040BED	1060 1060B 1060BED	2100 2100B 2100BED	2130 2130B 2130BED	3180 3180B 3180BED	3290 3290B 3290BED	4380 4380B 4380BED
Dimensioni Dimensions (mm)	P1	175	190	190	190	190	190	190
	P2	270	270	470	470	970	970	1245
	P3	-	-	-	-	-	-	622,5
	A	404	404	604	604	1104	1104	1379
	B	360	433	433	433	433	433	433
Attacchi Connections	Ø ingresso Ø inlet	9,52 mm	9,52 mm	9,52 mm	9,52 mm	1/2" SAE	1/2" SAE	1/2" SAE
	Ø uscita Ø outlet	9,52 mm	9,52 mm	9,52 mm	9,52 mm	16mm	16 mm	16 mm
	Ø scarico Ø drain	1/2" Gas(20mm)	1/2" Gas(20mm)	1/2" Gas(20mm)	1/2" Gas(20mm)	1/2" Gas(20mm)	1/2" Gas(20mm)	1/2" Gas(20mm)



Caratteristiche tecniche

Technical features

RIVACOLD

Serie RS / RS Range			3,5 - 7					Passo alette / Fin spacing	
Modello Model			1040	1060	2100	2130	3180	3290	4380
Capacità ΔT 10 T. cella 2°C Capacity ΔT 10 Room T. 2°C	W		406	595	741	1010	1390	1910	2360
Portata d'aria Air flow	m ³ /h		223	195	382	337	705	595	784
Freccia d'aria Air throw	m		3,0	2,5	3,0	2,5	3,0	2,5	2,5
Superficie totale Total surface	m ²		1,48	2,22	2,42	3,63	4,77	7,16	9,1
Peso netto Net weight	kg		4,0	4,6	6,7	7,3	10,5	11,5	16,5

Serie RS....B / RS....B Range			4,5 - 9					Passo alette / Fin spacing	
Modello Model			1040B	1060B	2100B	2130B	3180B	3290B	4380B
			1040BED	1060BED	2100BED	2130BED	3180BED	3290BED	4380BED
Capacità ΔT 10 T. cella -20°C Capacity ΔT 10 Room T. -20°C	W		346	474	579	707	1110	1380	1570
Portata d'aria Air flow	m ³ /h		243	213	426	382	773	684	866
Freccia d'aria Air throw	m		3,0	2,5	3,0	2,5	3,0	2,5	2,5
Superficie totale Total surface	m ²		1,18	1,78	1,94	2,9	3,82	5,72	7,28
Peso netto Net weight	vers. standard standard vers.	kg	3,9	4,5	6,6	7,2	10,4	11,4	16,3
	vers. ED ED vers.	kg	4,2	4,8	7,0	7,6	11,0	12,0	17,1

Serie RS-RS....B / RS-RS....B Range									
Modello Model			1040	1060	2100	2130	3180	3290	4380
			1040B	1060B	2100B	2130B	3180B	3290B	4380B
			1040BED	1060BED	2100BED	2130BED	3180BED	3290BED	4380BED
Volume circuito evaporatore Evaporator circuit volume	dm ³		0,38	0,58	0,60	0,91	1,15	1,73	2,19
Motoventilatori Fan motors	n x Ømm		1x200	1x200	2x200	2x200	3x200	3x200	4x200
Assorbimento motori (*) Motor power consumption	A		0,23	0,23	0,46	0,46	0,69	0,69	0,92
	W		38	38	76	76	114	114	152
Sbrinamento elettrico (*) Electrical defrost	W		400	400	600	650	1000	1000	1300

(*) Alimentazione elettrica 230V-1-50Hz / Power supply 230V-1-50Hz

RS1040

3,5 - 7 Passo alette / Fin spacing

Tc			-5°C	0°C	2°C	4°C	6°C	8°C	10°C	12°C
ΔT 10	UR/RH 76%	Watt	386	404	406	408	412	416	420	425
ΔT 9	UR/RH 79%	Watt	336	352	354	356	359	362	365	371
ΔT 8	UR/RH 82%	Watt	286	300	302	304	306	308	310	315
ΔT 7	UR/RH 85%	Watt	235	246	247	248	249	250	254	258
ΔT 6	UR/RH 89%	Watt	185	194	195	196	197	199	202	206
ΔT 5	UR/RH 93%	Watt	131	137	138	139	140	143	145	148

RS1040B RS1040BED

4,5 - 9 Passo alette / Fin spacing

Tc			-35°C	-30°C	-25°C	-20°C	-15°C	-10°C	-5°C	0°C
ΔT 10	UR/RH 76%	Watt	311	326	337	346	351	357	371	389
ΔT 9	UR/RH 79%	Watt	275	286	294	302	305	311	323	339
ΔT 8	UR/RH 82%	Watt	237	244	250	253	256	264	275	289
ΔT 7	UR/RH 85%	Watt	196	201	206	207	210	216	226	237
ΔT 6	UR/RH 89%	Watt	154	157	160	162	164	170	177	187
ΔT 5	UR/RH 93%	Watt	109	111	112	113	116	120	126	134

RS1060

3,5 - 7 Passo alette / Fin spacing

Tc			-5°C	0°C	2°C	4°C	6°C	8°C	10°C	12°C
ΔT 10	UR/RH 76%	Watt	557	589	595	600	605	610	618	635
ΔT 9	UR/RH 79%	Watt	487	515	520	523	527	536	545	556
ΔT 8	UR/RH 82%	Watt	422	446	449	451	453	458	472	482
ΔT 7	UR/RH 85%	Watt	354	376	379	382	385	389	397	405
ΔT 6	UR/RH 89%	Watt	288	307	310	313	316	320	328	335
ΔT 5	UR/RH 93%	Watt	217	232	234	236	239	244	250	257

RS1060B RS1060BED

4,5 - 9 Passo alette / Fin spacing

Tc			-35°C	-30°C	-25°C	-20°C	-15°C	-10°C	-5°C	0°C
ΔT 10	UR/RH 76%	Watt	385	420	449	474	490	506	532	563
ΔT 9	UR/RH 79%	Watt	351	378	401	416	429	448	470	499
ΔT 8	UR/RH 82%	Watt	312	333	351	362	372	388	407	432
ΔT 7	UR/RH 85%	Watt	269	285	297	305	313	326	342	364
ΔT 6	UR/RH 89%	Watt	222	233	239	244	253	264	278	297
ΔT 5	UR/RH 93%	Watt	170	176	179	183	189	198	209	224

TC = temperatura cella / cold room temperature

**R404A****Potenza frigorifera***Refrigerating output***RIVACOLD****RS2100**

3,5 - 7 Passo alette / Fin spacing

Tc			-5°C	0°C	2°C	4°C	6°C	8°C	10°C	12°C
ΔT 10	UR/RH 76%	Watt	693	733	741	748	754	760	770	792
ΔT 9	UR/RH 79%	Watt	614	651	656	660	666	677	688	701
ΔT 8	UR/RH 82%	Watt	533	564	568	570	573	579	596	608
ΔT 7	UR/RH 85%	Watt	449	476	480	484	488	492	502	511
ΔT 6	UR/RH 89%	Watt	365	388	392	396	400	405	413	423
ΔT 5	UR/RH 93%	Watt	271	289	291	294	297	304	311	319

RS2100B RS2100BED

4,5 - 9 Passo alette / Fin spacing

Tc			-35°C	-30°C	-25°C	-20°C	-15°C	-10°C	-5°C	0°C
ΔT 10	UR/RH 76%	Watt	459	509	543	579	610	629	663	703
ΔT 9	UR/RH 79%	Watt	420	455	488	516	542	558	587	623
ΔT 8	UR/RH 82%	Watt	376	404	429	450	471	484	509	541
ΔT 7	UR/RH 85%	Watt	327	346	365	382	390	408	429	456
ΔT 6	UR/RH 89%	Watt	269	285	298	310	317	331	348	372
ΔT 5	UR/RH 93%	Watt	208	217	225	233	237	249	263	281

RS2130

3,5 - 7 Passo alette / Fin spacing

Tc			-5°C	0°C	2°C	4°C	6°C	8°C	10°C	12°C
ΔT 10	UR/RH 76%	Watt	916	989	1010	1020	1040	1060	1080	1110
ΔT 9	UR/RH 79%	Watt	829	893	908	921	934	947	978	1000
ΔT 8	UR/RH 82%	Watt	734	791	802	811	821	836	864	886
ΔT 7	UR/RH 85%	Watt	626	673	679	685	691	714	733	751
ΔT 6	UR/RH 89%	Watt	525	567	571	574	583	605	622	639
ΔT 5	UR/RH 93%	Watt	416	450	456	463	470	484	498	513

RS2130B RS2130BED

4,5 - 9 Passo alette / Fin spacing

Tc			-35°C	-30°C	-25°C	-20°C	-15°C	-10°C	-5°C	0°C
ΔT 10	UR/RH 76%	Watt	478	559	635	707	765	826	890	960
ΔT 9	UR/RH 79%	Watt	450	522	586	647	695	748	803	866
ΔT 8	UR/RH 82%	Watt	417	479	531	581	620	664	711	766
ΔT 7	UR/RH 85%	Watt	378	426	470	503	538	574	614	660
ΔT 6	UR/RH 89%	Watt	332	367	401	425	452	481	514	555
ΔT 5	UR/RH 93%	Watt	273	299	318	337	357	379	406	440

TC = temperatura cella / cold room temperature

RS3180

3,5 - 7 Passo alette / Fin spacing

Tc			-5°C	0°C	2°C	4°C	6°C	8°C	10°C	12°C
ΔT 10	UR/RH 76%	Watt	1300	1380	1390	1400	1410	1420	1440	1480
ΔT 9	UR/RH 79%	Watt	1150	1220	1230	1240	1250	1270	1290	1310
ΔT 8	UR/RH 82%	Watt	1000	1060	1072	1084	1096	1108	1120	1140
ΔT 7	UR/RH 85%	Watt	841	890	897	905	913	921	940	958
ΔT 6	UR/RH 89%	Watt	684	727	735	743	751	759	775	792
ΔT 5	UR/RH 93%	Watt	515	551	556	561	566	580	594	609

RS3180B RS3180BED

4,5 - 9 Passo alette / Fin spacing

Tc			-35°C	-30°C	-25°C	-20°C	-15°C	-10°C	-5°C	0°C
ΔT 10	UR/RH 76%	Watt	920	991	1060	1110	1170	1200	1260	1330
ΔT 9	UR/RH 79%	Watt	828	892	945	990	1030	1060	1110	1180
ΔT 8	UR/RH 82%	Watt	735	786	826	861	882	919	964	1020
ΔT 7	UR/RH 85%	Watt	634	671	701	726	742	773	811	861
ΔT 6	UR/RH 89%	Watt	524	549	569	588	600	626	659	702
ΔT 5	UR/RH 93%	Watt	400	414	427	434	449	470	497	532

RS3290

3,5 - 7 Passo alette / Fin spacing

Tc			-5°C	0°C	2°C	4°C	6°C	8°C	10°C	12°C
ΔT 10	UR/RH 76%	Watt	1750	1880	1910	1940	1960	1990	2030	2090
ΔT 9	UR/RH 79%	Watt	1570	1690	1710	1740	1760	1780	1840	1880
ΔT 8	UR/RH 82%	Watt	1390	1490	1510	1520	1540	1570	1620	1660
ΔT 7	UR/RH 85%	Watt	1200	1280	1300	1310	1330	1360	1390	1430
ΔT 6	UR/RH 89%	Watt	989	1060	1070	1080	1090	1130	1160	1200
ΔT 5	UR/RH 93%	Watt	780	842	854	867	880	906	932	959

RS3290B RS3290BED

4,5 - 9 Passo alette / Fin spacing

Tc			-35°C	-30°C	-25°C	-20°C	-15°C	-10°C	-5°C	0°C
ΔT 10	UR/RH 76%	Watt	986	1130	1270	1380	1470	1580	1690	1810
ΔT 9	UR/RH 79%	Watt	922	1050	1160	1260	1330	1420	1520	1630
ΔT 8	UR/RH 82%	Watt	848	954	1040	1120	1180	1250	1340	1430
ΔT 7	UR/RH 85%	Watt	760	838	910	963	1020	1080	1150	1230
ΔT 6	UR/RH 89%	Watt	660	718	770	807	852	901	961	1030
ΔT 5	UR/RH 93%	Watt	534	577	605	636	669	708	755	817

TC = temperatura cella / cold room temperature

**R404A****Potenza frigorifera***Refrigerating output***RIVACOLD****RS4380**

3,5 - 7 Passo alette / Fin spacing

Tc			-5°C	0°C	2°C	4°C	6°C	8°C	10°C	12°C
ΔT 10	UR/RH 76%	Watt	2120	2300	2360	2400	2450	2490	2560	2640
ΔT 9	UR/RH 79%	Watt	1930	2100	2140	2180	2220	2260	2330	2400
ΔT 8	UR/RH 82%	Watt	1730	1870	1910	1930	1970	2010	2080	2140
ΔT 7	UR/RH 85%	Watt	1510	1640	1660	1680	1700	1760	1810	1860
ΔT 6	UR/RH 89%	Watt	1290	1400	1410	1430	1450	1510	1550	1600
ΔT 5	UR/RH 93%	Watt	1040	1130	1140	1150	1190	1230	1270	1310

RS4380B RS4380BED

4,5 - 9 Passo alette / Fin spacing

Tc			-35°C	-30°C	-25°C	-20°C	-15°C	-10°C	-5°C	0°C
ΔT 10	UR/RH 76%	Watt	1000	1200	1390	1570	1740	1890	2050	2240
ΔT 9	UR/RH 79%	Watt	995	1130	1290	1450	1600	1720	1870	2030
ΔT 8	UR/RH 82%	Watt	892	1040	1190	1320	1430	1540	1670	1810
ΔT 7	UR/RH 85%	Watt	820	947	1060	1170	1250	1350	1460	1580
ΔT 6	UR/RH 89%	Watt	731	831	921	993	1070	1150	1240	1350
ΔT 5	UR/RH 93%	Watt	621	693	759	808	853	915	996	1090

Dimensione imballi*Packages dimensions*

Codice Code	Dimensioni imballo evaporatore Evaporator package dimensions			
	A mm	B mm	H mm	Peso Weight Kg
RS1	432	455	155	0,8
RS2	632	455	155	1,0
RS3	1135	455	155	1,6
RS4	1410	455	155	2,5

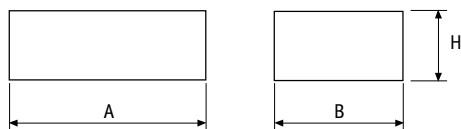

LETTURA CODICE / MODEL DESIGNATION

RS 1 040 B ED - VT

Batteria verniciata con vernice a polvere epossidica (optional)
Varnished coil by epoxy powder varnish (optional)

Con resistenze di sbrinamento
With defrosting heaters

Passo alette 4,5/9 (mm)
Fin spacing 4,5/9 (mm)

Codice identificazione modello
Model identification code

n° ventole
Fans No.

Serie
Range



NOTES

NOTES

Notes area containing 10 horizontal light blue lines for writing.



NOTES

RIVACOLD s.r.l.

Costruzione Gruppi Frigoriferi e Accessori

Via Sicilia, 7 - 61020 Montecchio PU - Italy

Tel. +39.0721.919911 - Fax +39.0721.490015

Internet: www.rivacold.com / E-mail: info@rivacold.com



A Member of **RIVACOLD GROUP** 